

HIGH-EFFICIENCY CD ACTUATOR DRIVER

PRODUCT PREVIEW

- WIDE OPERATIVE SUPPLY RANGE (1.6 to 7V) LOW VOLTAGE OPERATION CAPABILITY
- 4 LOAD DRIVING VOLTAGES PWM REGULATED (STEP DOWN FROM BATTERY)
- LOW ON RESISTANCE H BRIDGES (2 x 1.6Ω MAX + 2 x 2.5Ω MAX) FOR:
 - FOCUS AND TRACKING ACTUATORS
 - SLEDGE AND SPINDLE MOTORS
- SYNCHRONIZABLE SAWTOOTH OSCILLATOR
- CONFIGURABLE DC/DC CONVERTER FOR ADJUSTABLE MAIN POWER SUPPLY, WITH LOW ON RESISTANCE (0.3Ω MAX) SWITCH
- GENERAL ENABLE INPUT
- ADJUSTABLE WATCH DOG AND DELAYED POWER ON RESET FUNCTIONS

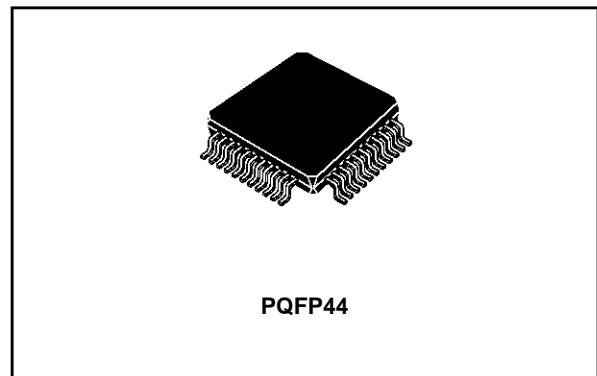

- ADJUSTABLE COMPARATORS FOR BATTERY LOW AND BATTERY EMPTY DETECTION

PIN CONNECTION

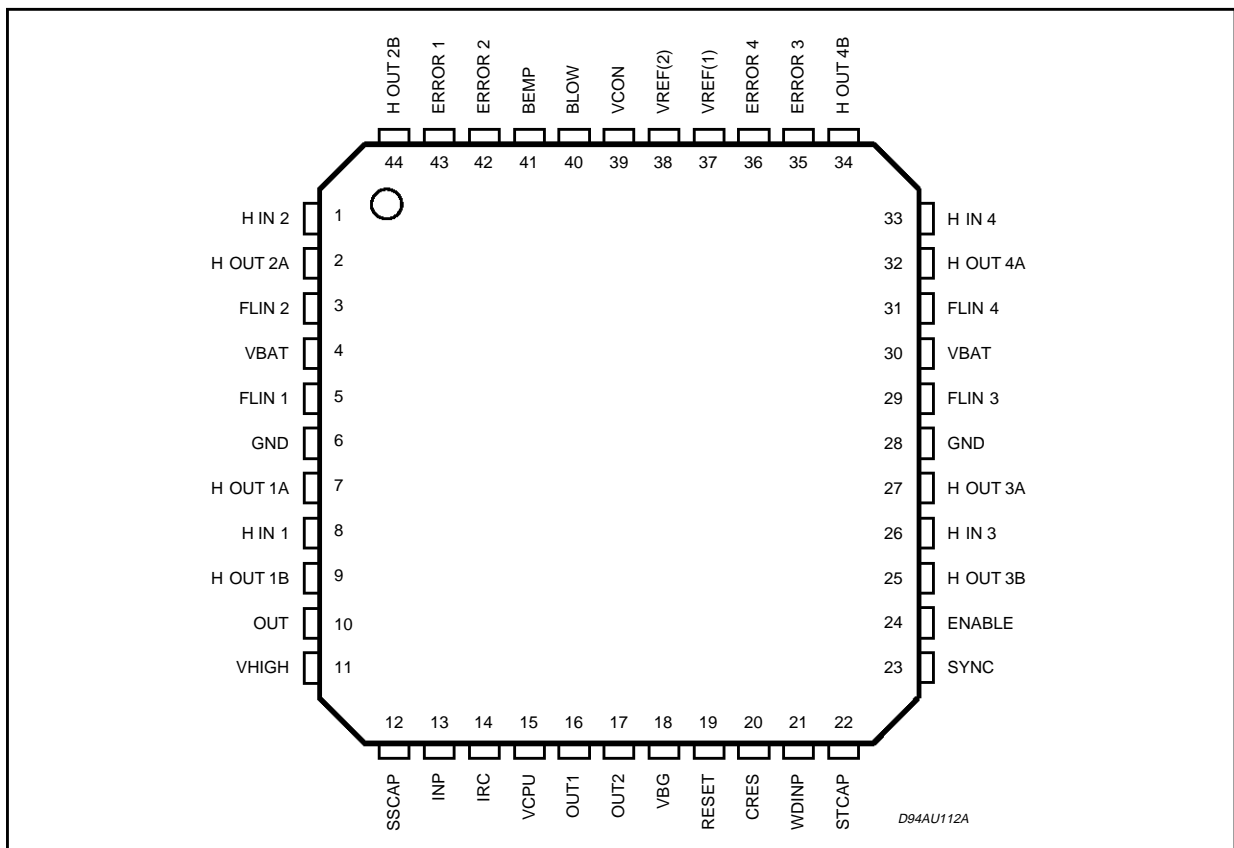

TDA7278

ABSOLUTE MAXIMUM RATINGS (25°C)

Pin Name	Min	Max	Unit
HIN 1, HIN 2, HIN 3, HIN 4	-0.4	8	V
HOUT 1A, HOUT 2A, HOUT 3A, HOUT 4A, HOUT 1B, HOUT 2B, HOUT 3B, HOUT 4B	-0.4	8	V
FLIN 1, FLIN 2, FLIN 3, FLIN 4	-0.4	10	V
ERROR 1, ERROR 2, ERROR 3, ERROR 4,	-0.4	7	V
V _{BAT}	-0.4	8	V
V _{REF 1} , V _{REF 2}	-0.4	7	V
BLOW, BEMP, V _{CON}	-0.4	7	V
OUT, VHIGH	-0.4	16	V
OUT 2	-0.4	8	V
OUT 1	-0.4	16	V
SSCAP, IRC, INP	-0.4	7	V
V _{CPU}	-0.4	7	V
VBG, RESET, CRES, WDINP, STCAP, SYNC	-0.4	7	V
EN	-0.4	8	V

THERMAL DATA

Symbol	Parameter	Value	Unit
T _{op}	Operating Temperature range	-25 to 70	°C
T _j	Max. Junction Temperature	100	°C
T _{J-amb}	Thermal Resistance Junction to Ambient	70	°C/W

PIN FUNCTIONS

N°	Name	Function	
21	WDINP	Watch dog input - AC coupled to WD μ controller output (Disabled when connected to GND)	Watch dog & reset circuit
20	CRES	Start up reset control for μ C & watch dog time constant	
19	RESET	Reset output command to μ C (open collector)	
41	BEMP	Battery empty comparator input	Battery control circuit
40	BLOW	Battery low comparator input	
39	VCON	Battery level control output VCON = Z VBEMP > VBCON > VBG VCON = 1 VBEMP > VBG > VBLOW VCON = 0 VBG > VBEMP > VBLOW	
24	ENABLE	General Enable Input (active Low)	Band Gap Reference
18	VBG	Reference voltage capacitor	
12	SSCAP	Soft start capacitor	VCPUC DC-DC converter
16	OUT 1	Switching transistor terminal high	
17	OUT 2	Switching transistor terminal low	
15	VCPUC	Regulated voltage	
14	IRC	Error amplifier output	
13	INP	Error amplifier inverting input	
11	VHIGH	Regulated Voltage	
10	OUT	Switching transistor output	Vhigh Boost DC-DC Converter
22	STCAP	Sawtooth toth	Oscillator
23	SYNC	Oscillator synchronizing input	
4, 30	V _{BAT}	Power supply voltage	
6, 28	GND	Power ground	
38	VREF 2	Buffered reference output voltage	
37	VREF 1	Reference input voltage	
5	FLIN 1	Switching Output	Focus actuator step down converter & H bridge
7	HOUT 1A	H bridge positive output	
8	HIN 1	Regulated voltage H bridge supply	
9	HOUT 1B	H bridge negative output	
43	ERROR 1	Error input	
29	FLIN 3	Switching Output	Tracking actuator step down converter & H bridge
27	HOUT 3A	H bridge positive output	
26	HIN 3	Regulated voltage H bridge supply	
25	HOUT 3B	H bridge negative output	
35	ERROR 3	Error input	
3	FLIN 2	Switching output	Spindle motor step down converter & H bridge
2	HOUT2A	H bridge positive output	
1	HIN 2	Regulated voltage H bridge supply	
44	HOUT 2B	H bridge negative output	
42	ERROR 2	Error input	
31	FLIN 4	Switching Output	Sledge motor step down converter & H bridge
32	HOUT 4A	H bridge positive output	
33	HIN 4	Regulated voltage H bridge supply	
34	HOUT 4B	H bridge negative output	
36	ERROR 4	Error input	

ELECTRICAL CHARACTERISTICS ($T_{amb} = 25^{\circ}\text{C}$, $V_{BAT} = 1.6\text{V}$ unless otherwise specified)

Symbol	Parameter	Test Condition	Min.	Typ.	Max.	Unit
V_{BAT}	Power Supply ($T_{amb} = 25$ to 70°C)	Config. in fig. 3a: $V_{CPU} < 4\text{V}$ Config. in fig. 3a: $V_{CPU} > 4\text{V}$ Config. in fig. 3b Config. in fig. 3c Stand-by condition Config. in fig 3a	1.6 $V_{CPU} + 0.3$ 1.6		V_{CPU} 4 4 4 4	V V V V V
	Power Supply ($T_{amb} = 25$ to 60°C)	Config. in fig. 3a Config. in fig. 3b Config. in fig. 3c Stand-by condition Config. in fig 3a	1.6 $V_{CPU} + 0.3$ 1.6		V_{CPU} 5 5 5	V V V V
	Current Consumption from V_{CPU} (1)	$V_{CPU} = 5$		5		mA
	Current Consumption from V_{BAT} (3)			1.5		mA
	Leakage Current in stand-by condition	$V_{BAT} = 5$			20	μA
V_{HIGH} V_{CPU} (adj)	Output Voltages		$V_{BAT} + 4$ 2.4	$V_{BAT} + 7$	$V_{BAT} + 12$ 5	V V
	R_{ON} of DC/DC Converter Switch	$I = 1\text{A}$		0.25	0.4	Ω
	Max Output Current from V_{CPU}	$V_{CPU} < 4.5\text{V}$ Config. fig 3a	150			mA
	Voltage Ripple on V_{CPU}					
	Oscillator - free freq. - sync. freq - Δ free freq.	STCAP = 470pF . $V_{BAT} = 16$ to 5V	80	200	180 20	KHz KHz KHz
	H_bridge - Ron, actuators (CH 1,3) - Ron, motors (CH 2,4)	$I = 100\text{mA}$		1.0 1.6	1.6 2.5	Ω Ω
	PWM Circuit - Ron, actuators - Ron, motors	$I = 100\text{mA}$		0.5 0.8	0.8 1.25	Ω Ω
V_{BG}	Reference Voltage		1.22	1.28	1.34	V
	Load Regulation	$I_{LOAD} = -10$ to $+10\mu\text{A}$;	-30		30	mV
	Line Regulation	$V_{BAT} = 1.6$ to 5V			30	mV
AV	Bridge gain	From Error to H_{IN}	2.8	3.6	4.5	
K	Reset Time Coefficient	note 2	7.4	11	17.2	msec/ μF
Z_{IN}	Error Impedance Inputs		26	40		k Ω
	V_{REF2} Load Regulation	$I_{LOAD} = -1$ to $+1\text{mA}$	-30		30	mV
	V_{REF1} Impedance			750		k Ω
	WINDIP Impedance			30		k Ω
	BEMP & BLOW intervention threshold		0.55	0.65	0.75	V
	RESET Voltage Saturation	$I_{LOAD} = -100\mu\text{A}$			200	mV
	VCON Voltage Saturation	$I_{LOAD} = -100\mu\text{A}$ $I_{LOAD} = 100\mu\text{A}$	$V_{CPU} - 200$		200	mV mV

(1): all the 4 PWM outputs switched off.

(2) $T_{RESET} = \text{width of the Reset pulse on pin 19} = K \cdot C$, where C is the capacitance on pin 20 (C_{RES}).
To avoid reset, the frequency of watch dog pulses must be greater than $(3 \cdot T_{RESET})^{-1}$

(3) All the 4 PWM output switched OFF, auxiliary and main DC/DC converters polarized but not switching

Figure 1: Block Diagram.

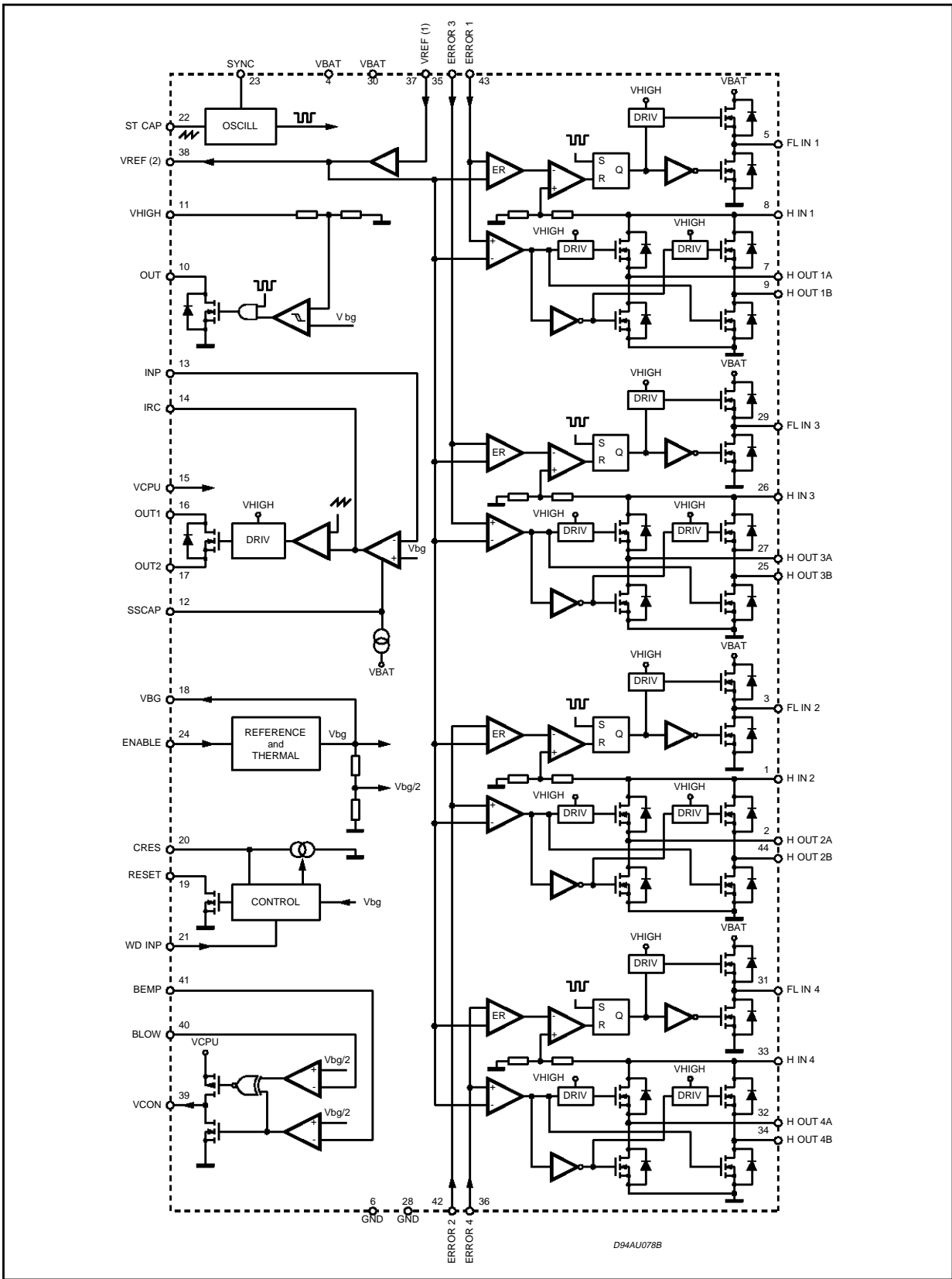

Figure 2: Test Circuit

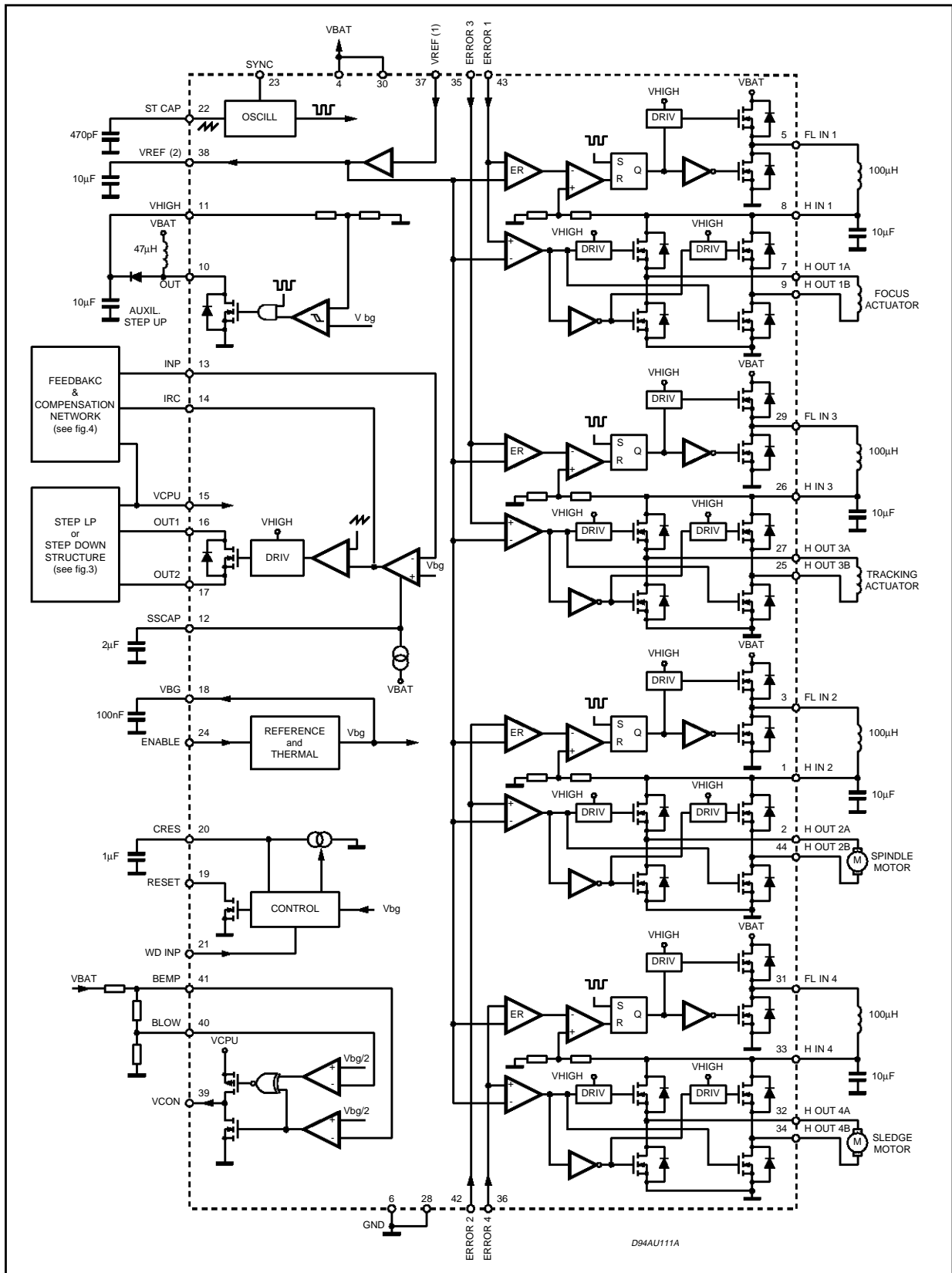

Figure 3: DC – DC Converter Configuration.

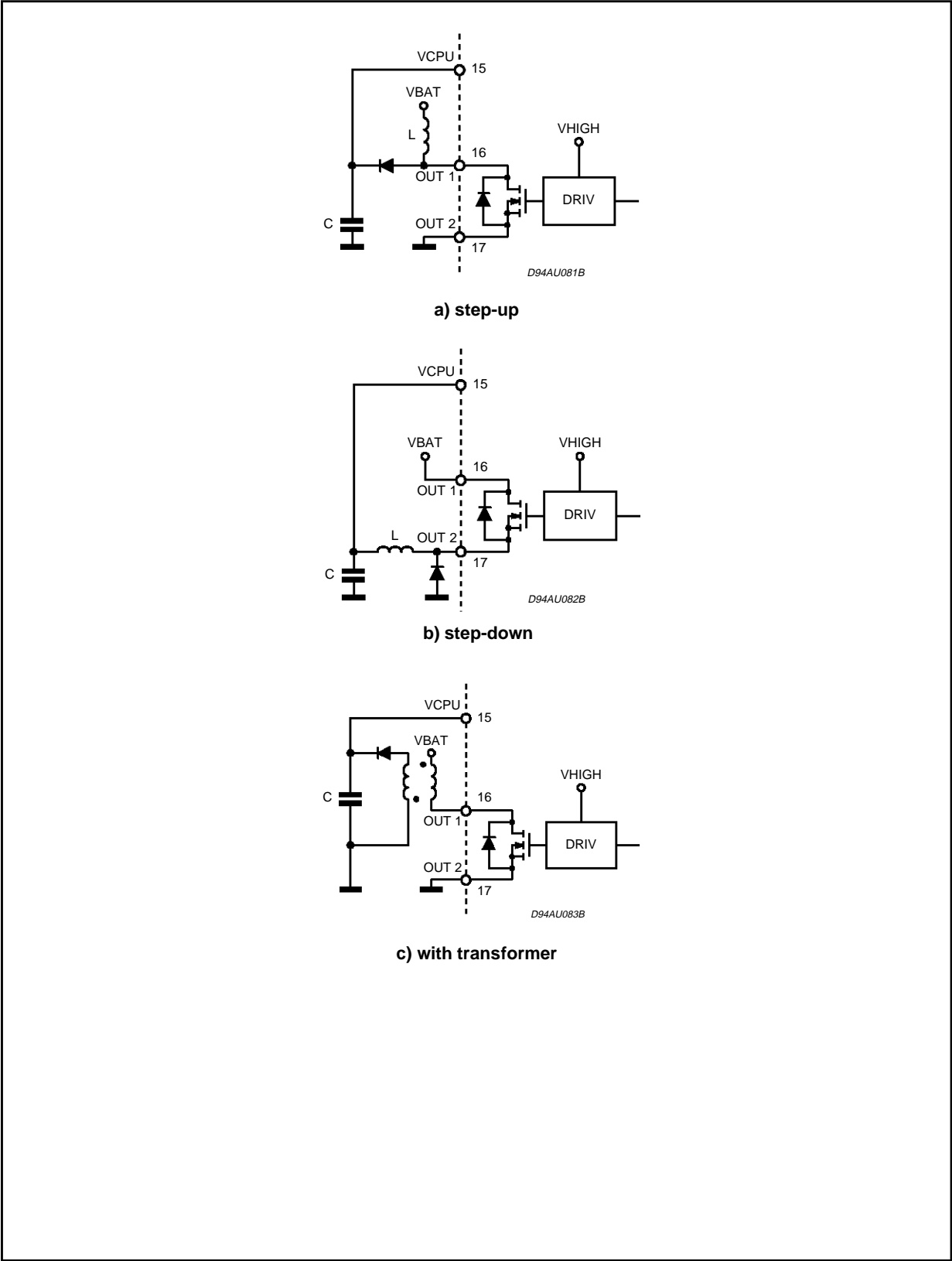
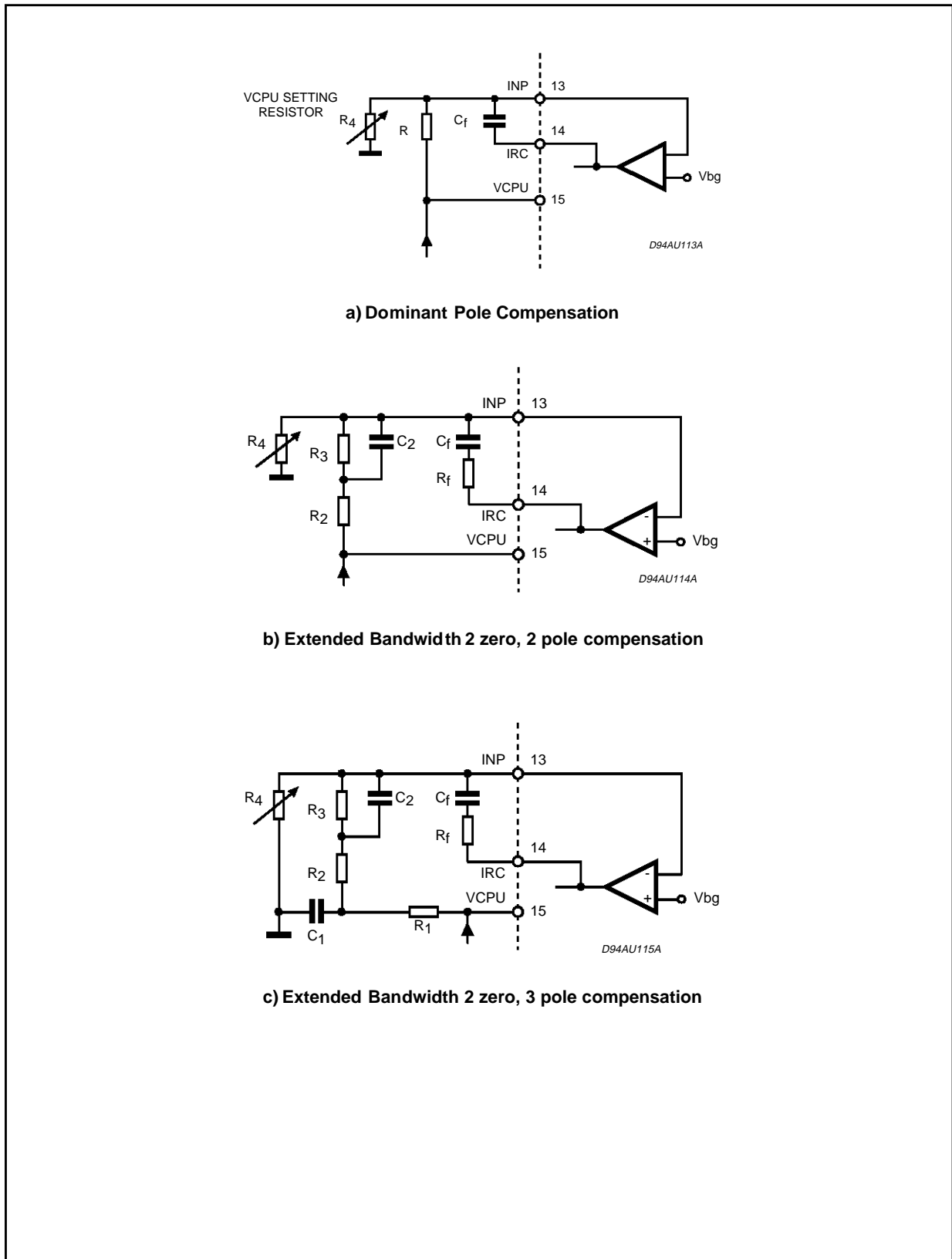

Figure 4: DC – DC Converter: Feedback and Compensation Networks.



SUGGESTED VALUES FOR OUTPUT FILTER AND COMPENSATION NETWORK

DC- DC CONVERTER CONFIGURATIONS	OUTPUT FILTER (see fig. 3)	COMPENSATION (see fig. 4)
STEP-DOWN	L = 47μH C = 47μF	a) DOMINANT POLE R = 50KΩ Cf = 47nF R4 = 35KΩ
		b) 2 ZERO, 2 POLE R2 = 11.18KΩ R3 = 100 KΩ C2 = 936pF Rf = 16.65KΩ Cf = 5.6nF R4 = 70KΩ
STEP-UP AND TRANSFORMER	L = 47μH C = 47μF	a) DOMINANT POLE R = 100KΩ Cf = 220nF R4 = 70KΩ
		c) 2 ZERO, 3 POLE R1 = 500Ω C1 = 18nF R2 = 20.8KΩ R3 = 250KΩ C2 = 636pF Rf = 21.4KΩ Cf = 7.44nF R4 = 200KΩ
	L = 11μH C = 47μF	c) 2 ZERO, 3 POLE R1 = 500Ω C1 = 18nF R2 = 10.4KΩ R3 = 250KΩ C2 = 318pF Rf = 21.4KΩ Cf = 3.7nF R4 = 200KΩ

PINS: 1, 2, 44

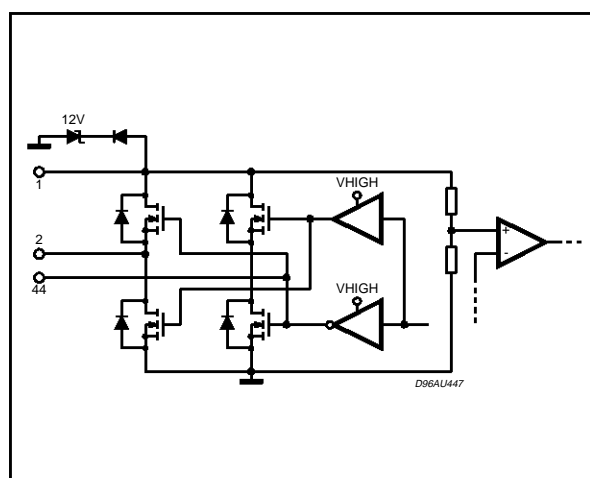

PINS: 8, 7, 9

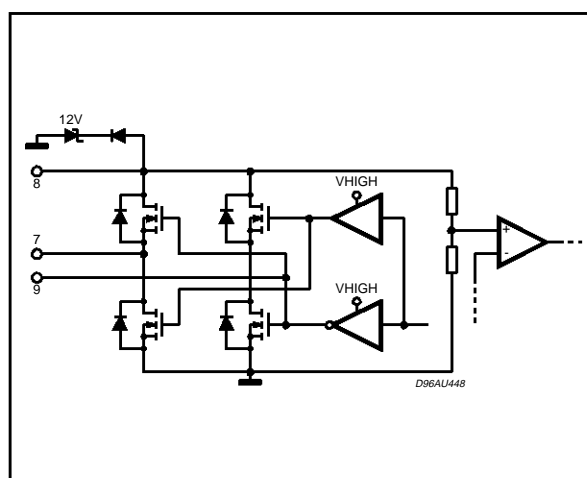

PINS: 25, 26, 27

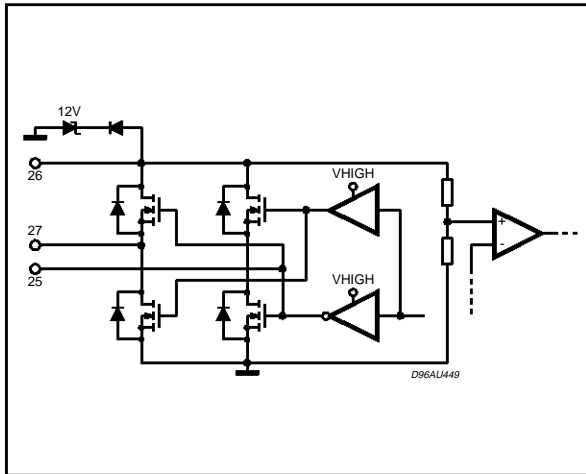

PINS: 32, 33, 34

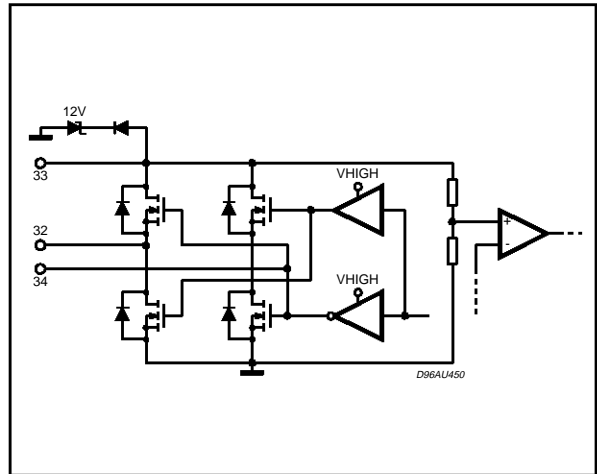

PIN: 3

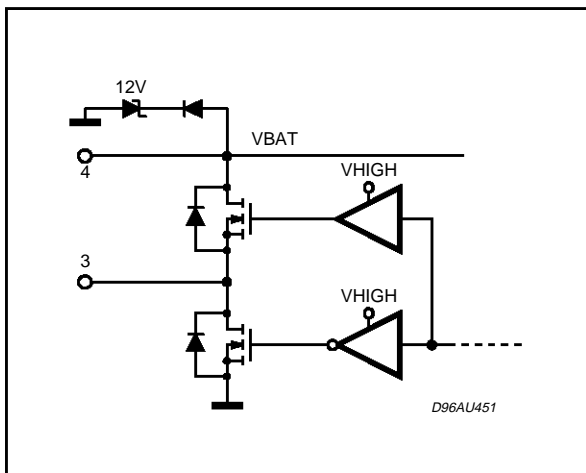

PINS: 5

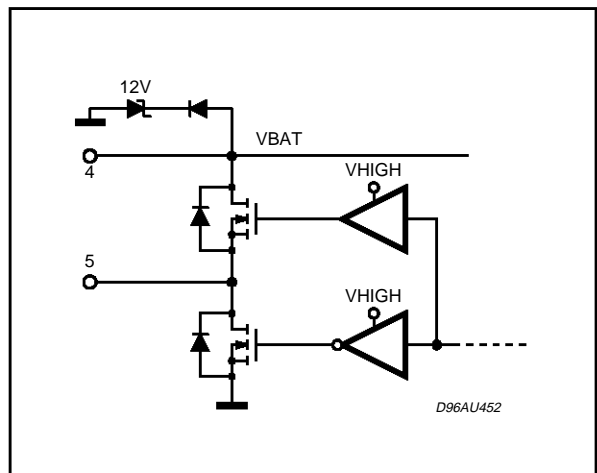

PIN: 29

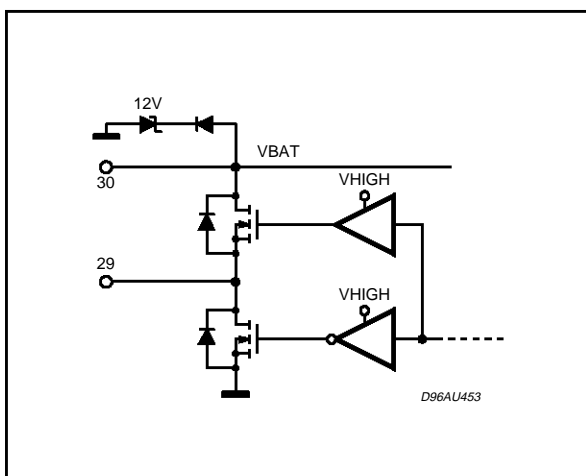

PINS: 31

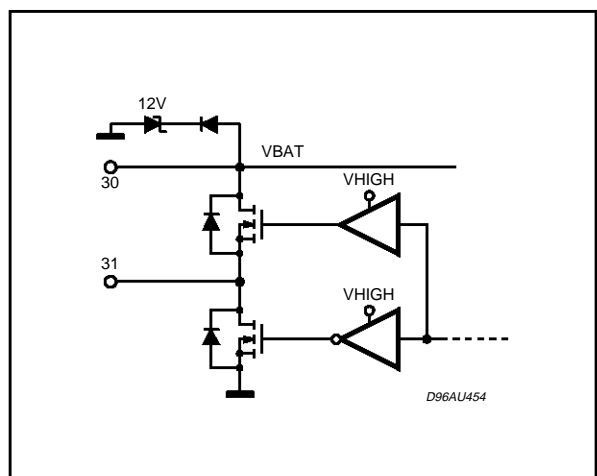

PINS: 16, 17

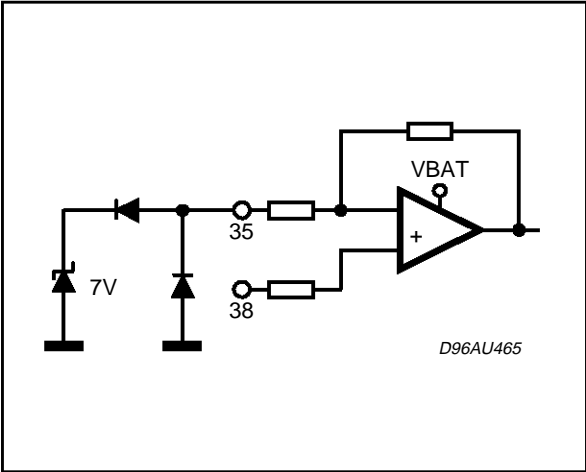

PIN: 18

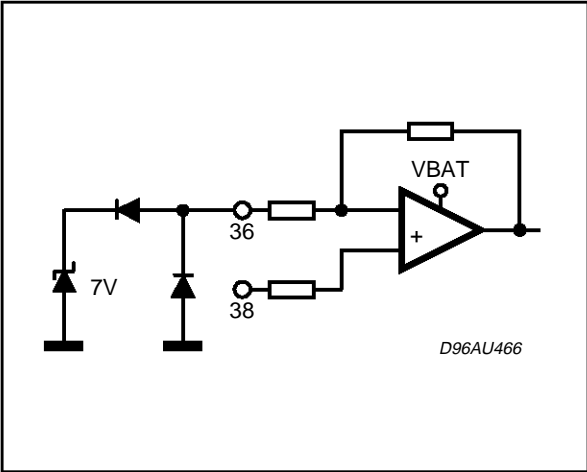

PIN: 19

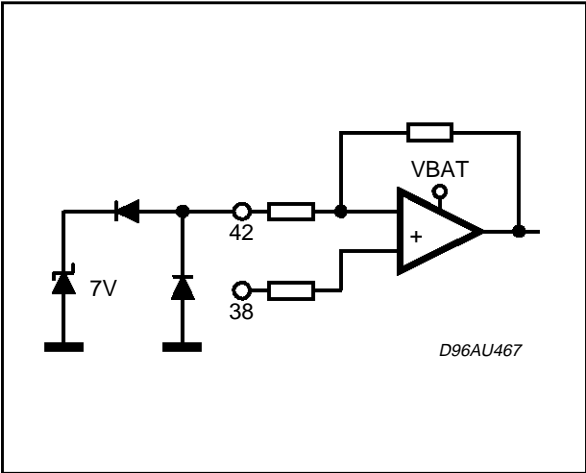

PIN: 20

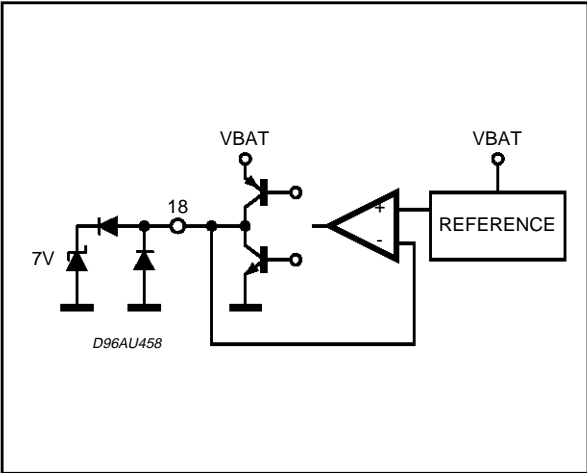

PINS: 10, 11

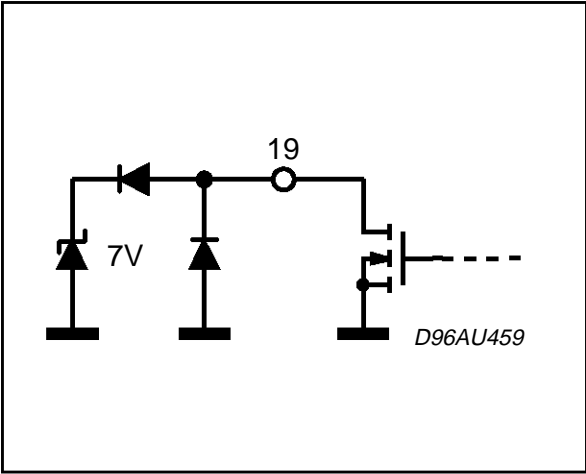

PINS: 12, 13, 14

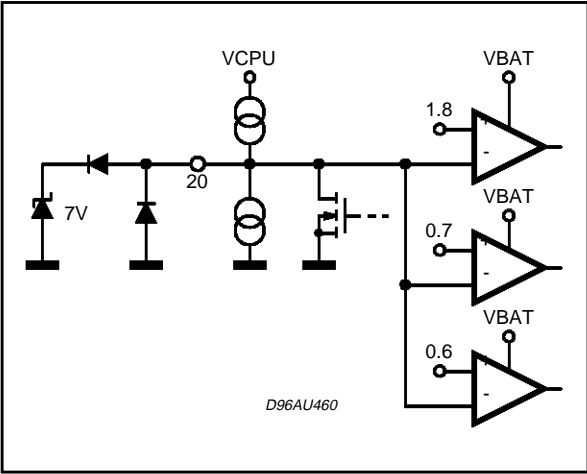

PINS: 16, 17

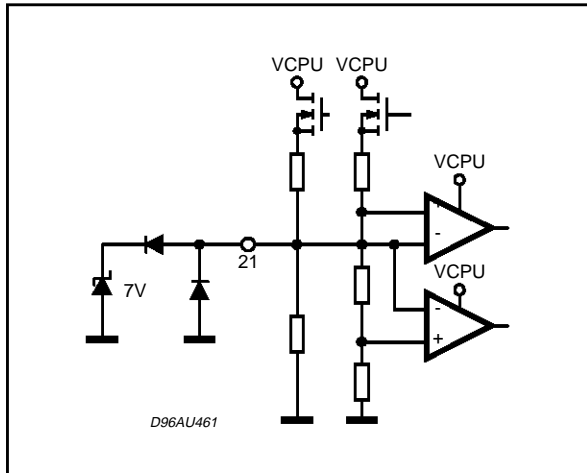

PIN: 18

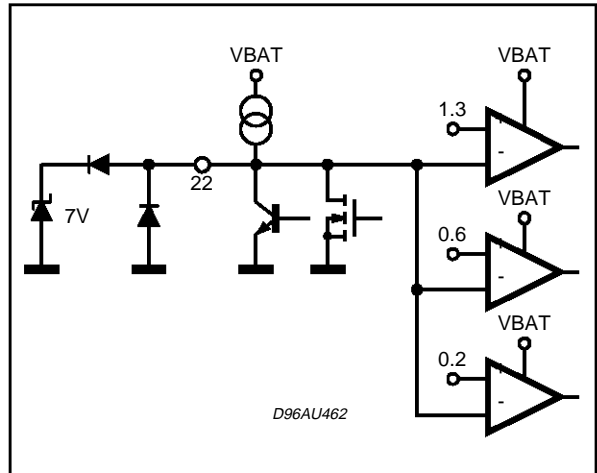

PIN: 19

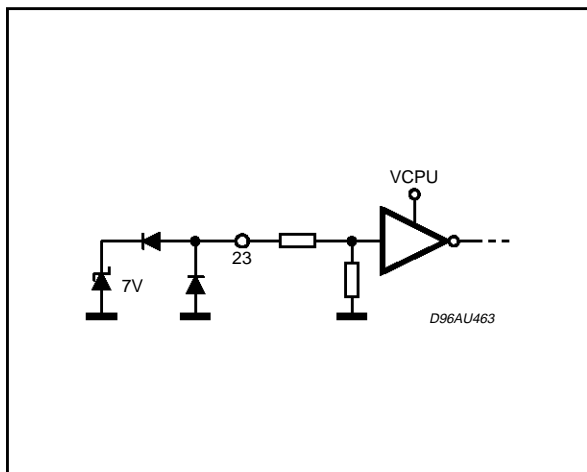

PIN: 20

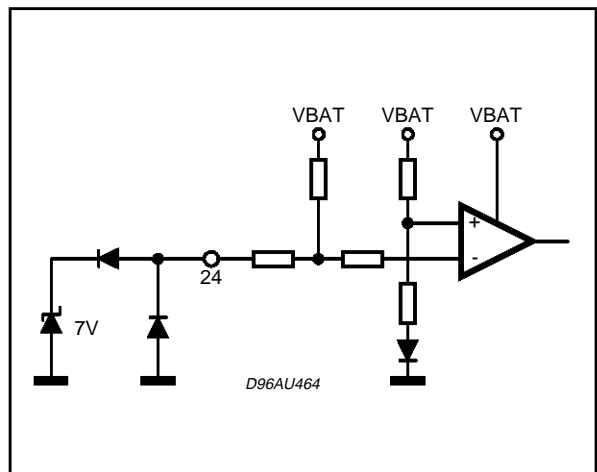

PIN: 21

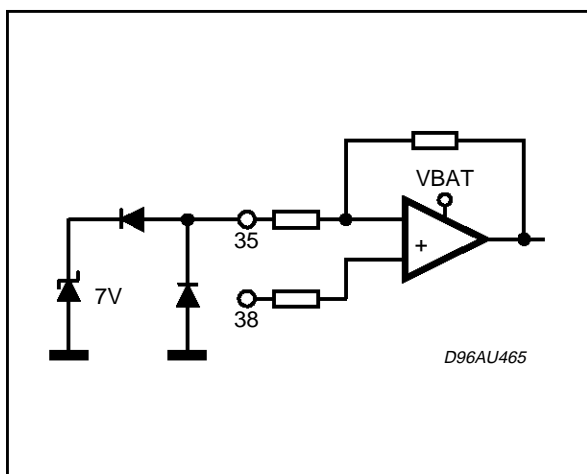

PIN: 22

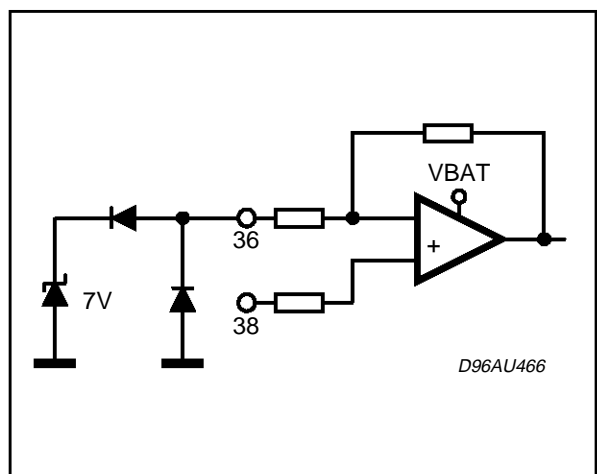

PIN: 23

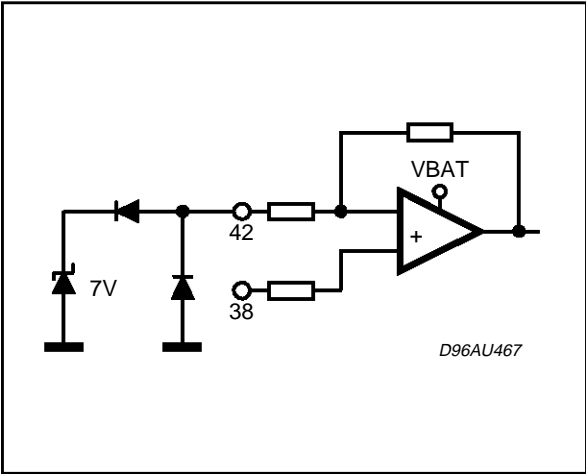

PIN: 24

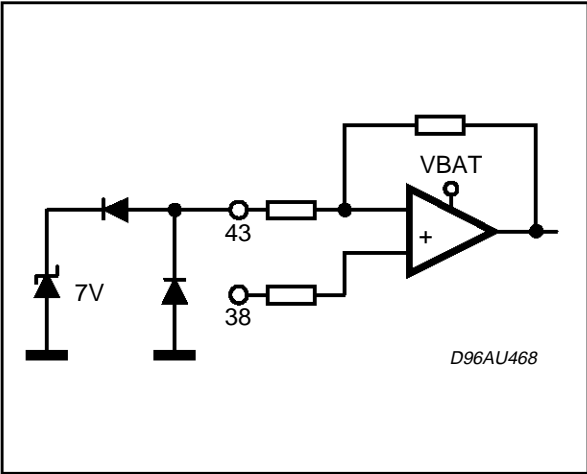

PIN: 35

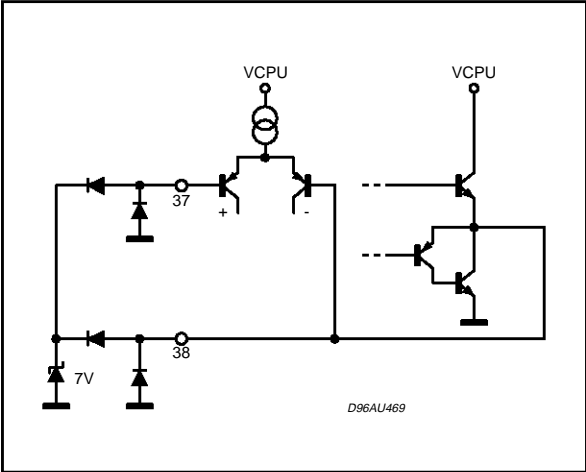

PIN: 36

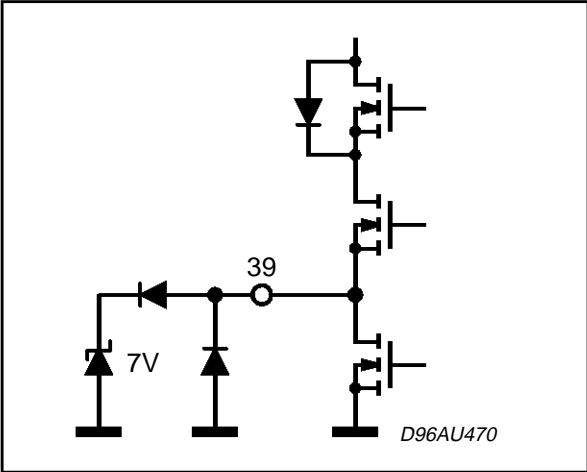

PIN: 42

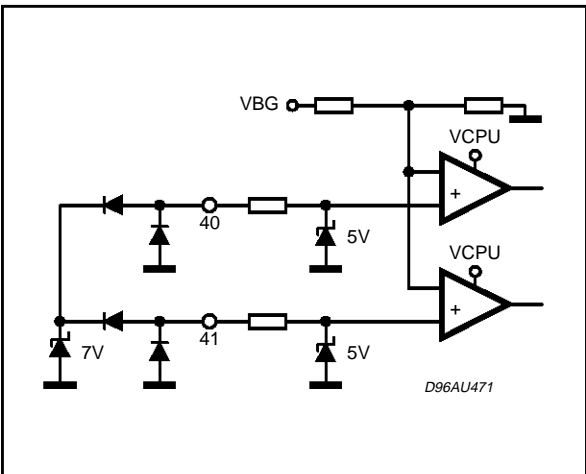

PQFP44 (10x10) PACKAGE MECHANICAL DATA

DIM.	mm			inch		
	MIN.	TYP.	MAX.	MIN.	TYP.	MAX.
A			2.45			0.096
A1	0.25			0.010		
A2	1.95	2.00	2.10	0.077	0.079	0.083
B	0.30		0.45	0.012		0.018
c	0.13		0.23	0.005		0.009
D	12.95	13.20	13.45	0.51	0.52	0.53
D1	9.90	10.00	10.10	0.390	0.394	0.398
D3		8.00			0.315	
e		0.80			0.031	
E	12.95	13.20	13.45	0.510	0.520	0.530
E1	9.90	10.00	10.10	0.390	0.394	0.398
E3		8.00			0.315	
L	0.65	0.80	0.95	0.026	0.031	0.037
L1		1.60			0.063	
K	0°(min.), 7°(max.)					

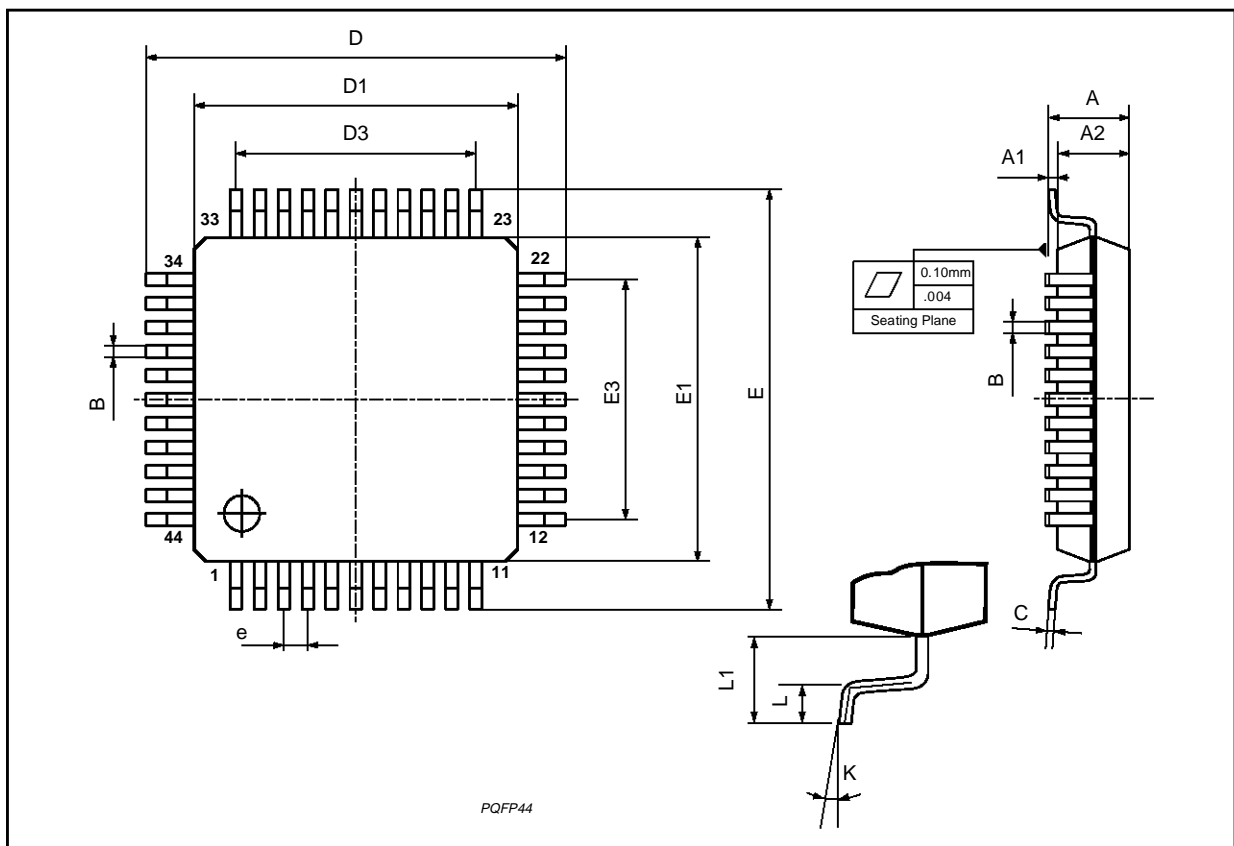

Information furnished is believed to be accurate and reliable. However, SGS-THOMSON Microelectronics assumes no responsibility for the consequences of use of such information nor for any infringement of patents or other rights of third parties which may result from its use. No license is granted by implication or otherwise under any patent or patent rights of SGS-THOMSON Microelectronics. Specifications mentioned in this publication are subject to change without notice. This publication supersedes and replaces all information previously supplied. SGS-THOMSON Microelectronics products are not authorized for use as critical components in life support devices or systems without express written approval of SGS-THOMSON Microelectronics.

© 1995 SGS-THOMSON Microelectronics All Rights Reserved

SGS-THOMSON Microelectronics GROUP OF COMPANIES

Australia - Brazil - France - Germany - Hong Kong - Italy - Japan - Korea - Malaysia - Malta - Morocco - The Netherlands - Singapore - Spain - Sweden - Switzerland - Taiwan - Thailand - United Kingdom - U.S.A.